

www.lanbaosensor.com



Precautions

- Please make sure that the power supply voltage is within the rated voltage range before powering on
- The time from powering-on to normal detection of the sensor is 100ms, please ensure that the sensor is used after 100ms of powering-on
- When using different power sources for the sensor and load, be sure to turn on the power of the sensor first
- When the sensor is not used, it is recommended to cut off the power of the load first and then turn off the power of the sensor
- Do not subject the sensor to severe external forces (such as hammer hits, etc.) during installation, so as not to damage the sensor performance
- Avoid using thinner, alcohol or other organic solvents when cleaning

Safety Warning

- Do not use in an environment with flammable, explosive or corrosive gases
- Do not use in oil or chemical environments
- Do not use in a high humidity environment
- Do not use in direct sunlight
- Do not use in other environmental conditions that exceed the rated value
- Do not disassemble, service or modify this product without authorization

Scrap Treatment

- When the product is scrapped, please dispose of it as industrial waste

Specifications

Receiver and Emitter	
Model	PDM-TC50TGR
Measuring range	Width mode: 10mm; Edge mode: ±5mm
Installation distance	0...500mm
Minimum sensing object	∅1mm (Setting distance: 500 mm) ^①
Light source	Red laser (Laser level: Class 1)
Light spot size	14*12mm
Supply voltage	12...24VDC
Voltage drop	<2.5V
Linear accuracy	±0.28%F.S.
Repeat accuracy	10µm (Setting distance: 100 mm) ^② ; 15µm (Setting distance: 500 mm) ^②
Dimension	Cast light: 55*32*23mm; Receive light: 55*32*23mm
Temperature drift	±0.08 %F.S./°C (±8µm/°C)
Indicator(Emitter)	Optical axis alignment indication: green LED; power indicator: green LED
Indicator(Receiver)	Optical axis alignment indication: green LED; position display: dual bar LEDs (yellow, green)
Anti ambient light	Incandescent: <3,000lux
Protection degree	IP50
Ambient temperature	-10...45°C (No frost)
Environment humidity	35...85% RH (No frost)
Material	Housing: Aluminium
Connection	PVC cable

Controller	
Supply voltage	12...24VDC
Consumption current	≤900mA (Including receiver/emitter)
Display resolution	1 µm
Display range	-99.999...99.999
Display mode	Two-digit 8 segment display; upper and lower levels: red, 6 digit
Response time	2ms
Output 1	NPN NO
Output 2	RS485 Output
Ambient temperature	-10...45°C (No freezing)
Environment humidity	35...85%RH (No frost)
Material	Housing: Plastic
Installation	Guide rail installation

Remarks: ①When the installation distance is 100mm, the light is blocked at the position 50mm away from the receiver. The margin of error to the ideal straight line.
②When the light is blocked by half at the middle position of the installation distance. Average times is set to 16 and sampling for 30 seconds.

Panel introduction

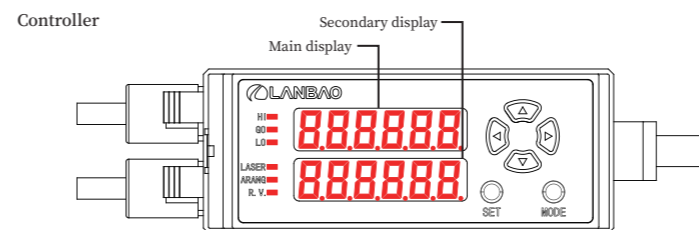

● Button

SET	Setting Button
MODE	mode Button

● Display

Main display	①Result display	②Menu display
Secondary display	①Result display	②Sub function display

*Note: The digital tube above when facing the controller.

● Indicator

Name	Color	Normal on / Normal off
LASER	Green	Laser tube status
HI	Green	Switch HIGH status
GO	Green	Switch GO status
LO	Green	Switch LOW status
A.RANG	Green	Emitter and receiver optical axis alignment

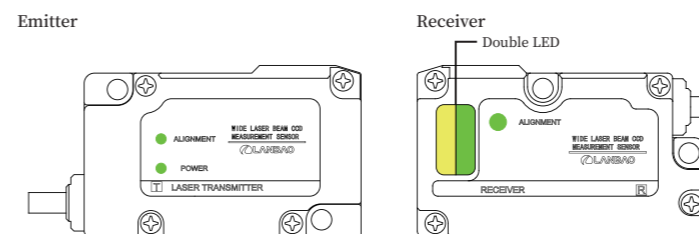

Emitter: Indicator

Name	Color	Normal on / Normal off
ALIGNMENT	Green	Emitter and receiver optical axis alignment
POWER	Green	Power indicator

Receiver: Indicator

Name	Color	Normal on / Normal off
ALIGNMENT	Green	Emitter and receiver optical axis alignment
DOUBLE LED	Yellow/Green	Measurement status in different measurement modes

Operation instruction

1. Install emitter and receiver in alignment, and connect to controller, then power on controller.
Emitter: POWER indicator on, ALIGNMENT indicator on
Controller: ALIGNMENT indicator on, double (red/green) indicator on
Controller: POWER indicator on, A.RANG indicator on, if there is no sensing object, the display shows: -----

2. Waveform login

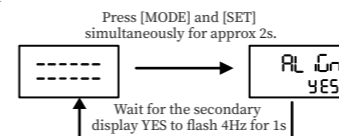

3. Basic settings

Operating mode (Upper computer/key): width mode, edge mode; Measurement direction (upper computer/key): top, bottom.

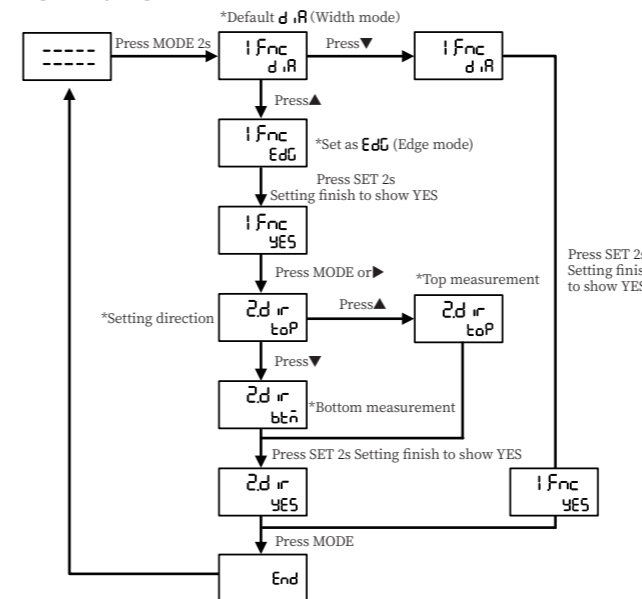

Data transmission protocol

- ◆ Baud rate: 115200 (default)
 - ◆ Parity: none
 - ◆ Number of data digits: 8 digits
 - ◆ Stop bit: 1 bit
 - ◆ Slave default address: 0x80
- Note: The default address is 0x80. Different slave addresses or different baud rates have different redundancy checks.

Master request message format:

Slave address	Function code	Data start address	Data amount (unit: word)	Redundancy check
80	03	00	50	MSB:00 LSB:01 LSB:9A MSB:0A

Slave response message format:

Slave address	Function code	Bytes	Data 1	Redundancy check
80	03	02	MSB LSB	LSB MSB

Note: MSB: means the high byte of double-byte data; LSB: means the low byte of double-byte data (the same below)

The host communicates by RS485, the sensor data read out needs to be calculated by the following methods to obtain the actual measurement value.

1. The fourth and fifth bytes in the response message of the slave are converted into decimal.
2. Actual measured value = the value of the 4th and 5th bytes divided by 1000, unit in mm.
3. When the MSB and LSB in the response message are both FF, it means the measurement result exceeds the range and displays "FFFF".

Example: For a product with a width of 5.27mm, the master requests a message:
80 03 00 50 00 01 9A 0A

Slave response message: 80 03 02 14 97 CA F4
The 4th and 5th bytes of the response message from the slave station are 14 97, converted to decimal as 5271. The actual measured value: 5271/1000 = 5.271mm.

Mode instruction

1. Edge mode: locate the edge position of the sensing object. The sensing object is classified into shading objects and transparent objects. Measurement direction includes top measurement and bottom measurement.

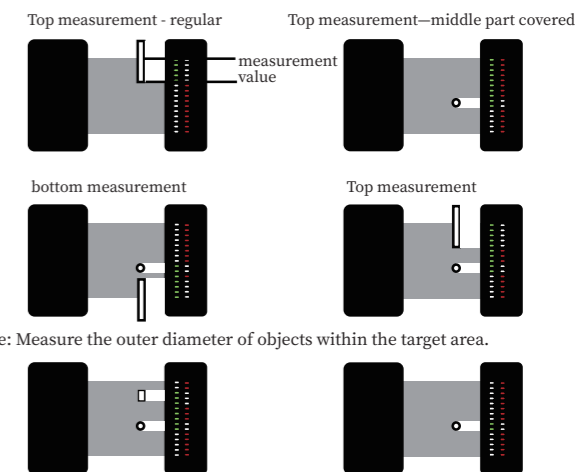

2. Width Mode: Measure the outer diameter of objects within the target area.

Installation

DIN rail mounting

1. Align groove on the bottom with the DIN rail as shown in the picture 1. While pushing the body forward in the direction of the arrow 1, press it in the direction of the arrow 2.
2. To remove the sensor, push the body forward in the direction of the arrow 1 while raising it in the direction of the arrow 3.

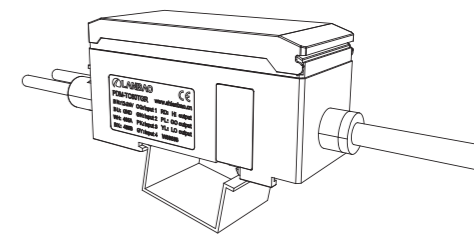

Wiring diagram

Brown	12-24V
Blue	GND
Orange	Input1
Green	Input2
White	485A
Black	485B
Pink	Input3
Grey	Input4
Red	HI output
Purple	GO output
Yellow	LO output

PDM-2022LB V1.1

This specification doesn't relate to patent responsibility. Moreover, our company is always devoting to improving product quality, and reserves the right to improve products by changing pattern or size without prior notice. We have considered all the notes when compiling this specification, but for the wrong or clipped parts, and any loss caused by using this manual information, we bear no responsibility.

Shanghai Lanbao Sensing Technology Co., Ltd.
Address: No 228, Jinbi Road, Jinhui Industrial Park, Fengxian Area, Shanghai, China
Zip code: 201404
TEL: 021-57486188 57486181
FAX: 021-57486199
Email: market@shlanbao.cn
Hotline: 800-820-8259

